

USL120070-2

12V7AH

3-5 YEARS DESIGN LIFE



Container Color
 ■ Black C
 ■ Grey 3 C

Plane Chart:

Unit:(mm) Terminal type:(F2)

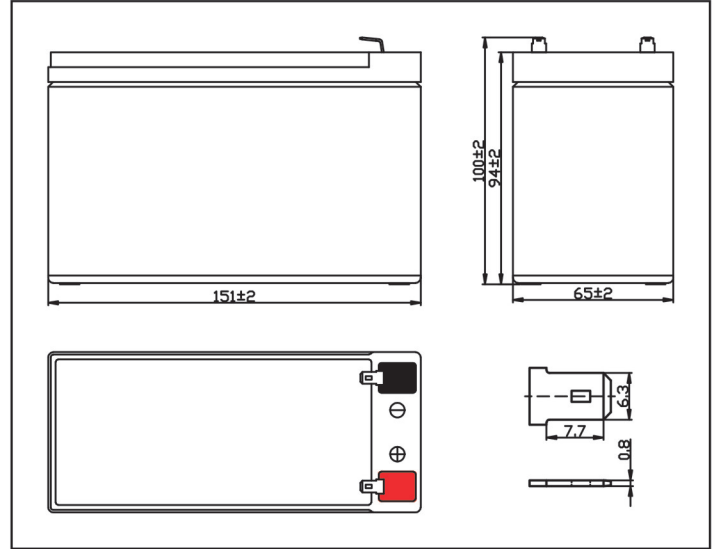

Parameter Chart:

Volts		12V
Capacity(25°C)	20 hours rate (0.35A)	7Ah
Discharge Current Testing (25°C)	20 I ₂₀ rate (6.5A,27min)	30min
	60 I ₂₀ rate (19.5A,7min)	7min
Internal Resistance	Full Charged Battery 25°C	30mΩ
Capacity Affected By Temperature	40°C	104%
	25°C	100%
	0°C	83%
	-15°C	65%
Residual Capacity (25°C)	Capacity After 3 Months Storage	91%
	Capacity After 6 Months Storage	82%
	Capacity After 12 Months Storage	65%
Charge (Constant Voltage)	Cycle (25°C)	Initial Charging Current Less Than 2.1A Voltage 14.5~14.9V
	Float (25°C)	Charge Voltage 13.6~13.8V
Weight (Approx)		1.95Kg

Residual Capacity

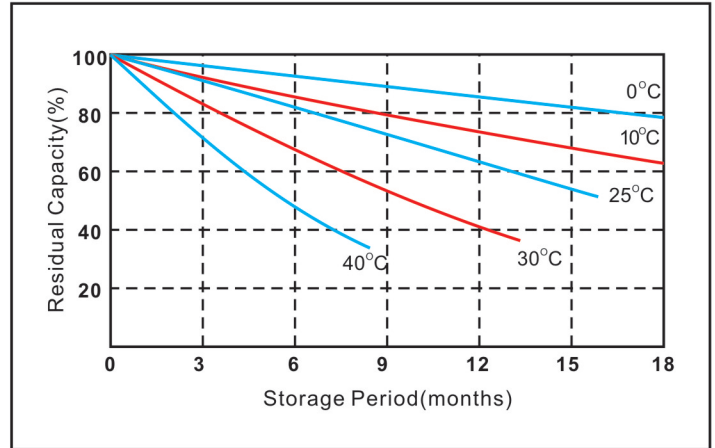

Discharge Current 25°C

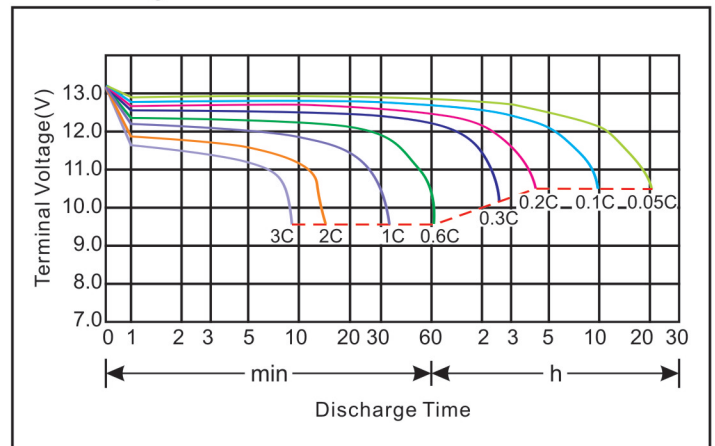

★The above are average and data obtained from the first 3 charge/discharge cycles. These are not minimum values.

USL120070-2

12V7AH

3-5 YEARS DESIGN LIFE

Constant voltage charging characteristics

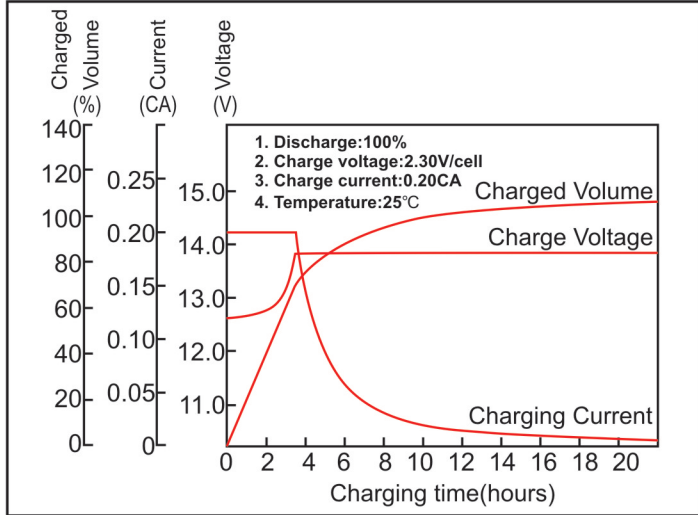

Float Life

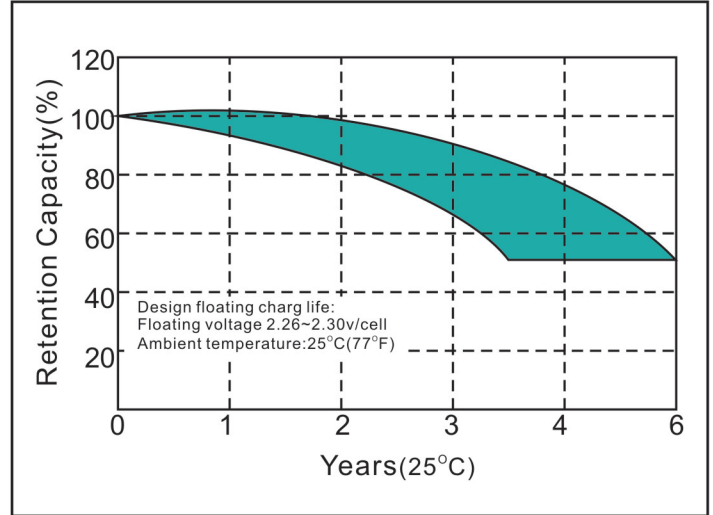

Constant Current Discharge Characteristics (A, 25°C)

F.V/Time	5min	10min	15min	30min	60min	2h	3h	5h	8h	10h	20h
9.60V	24.30	16.20	12.60	6.60	4.23	2.24	1.56	1.06	0.73	0.64	0.33
10.2V	22.20	15.10	11.80	6.50	4.10	2.18	1.53	1.04	0.71	0.63	0.33
10.5V	19.80	14.20	11.30	6.40	3.96	2.16	1.51	1.02	0.70	0.62	0.32
10.8V	18.50	10.80	10.80	6.20	3.91	2.13	1.49	1.00	0.69	0.61	0.32

Constant Current Discharge Characteristics (Watt, 25°C)

F.V/Time	5min	10min	15min	30min	60min	2h	3h	5h	8h	10h	20h
9.60V	262.50	176.60	138.60	73.92	48.20	25.80	18.10	12.40	8.60	7.60	3.93
10.2V	244.20	167.60	132.20	73.45	46.70	25.10	17.80	12.20	8.40	7.50	3.90
10.5V	219.80	159.20	127.70	72.96	45.50	25.30	17.60	12.10	8.40	7.40	3.80
10.8V	207.20	122.10	123.10	71.30	44.90	24.90	17.40	11.80	8.20	7.30	3.75

Capacity Factors With Different Temperature

Battery Type		-20°C	-10°C	0°C	5°C	10°C	20°C	25°C	30°C	40°C	45°C
Battery	12V	50%	70%	83%	85%	90%	98%	100%	102%	104%	105%

★The above are average and data obtained from the first 3 charge/discharge cycles. These are not minimum values.